

# Cahier de processus Iqaluk

Rosalie Charbonneau et Antoine Sarrazin

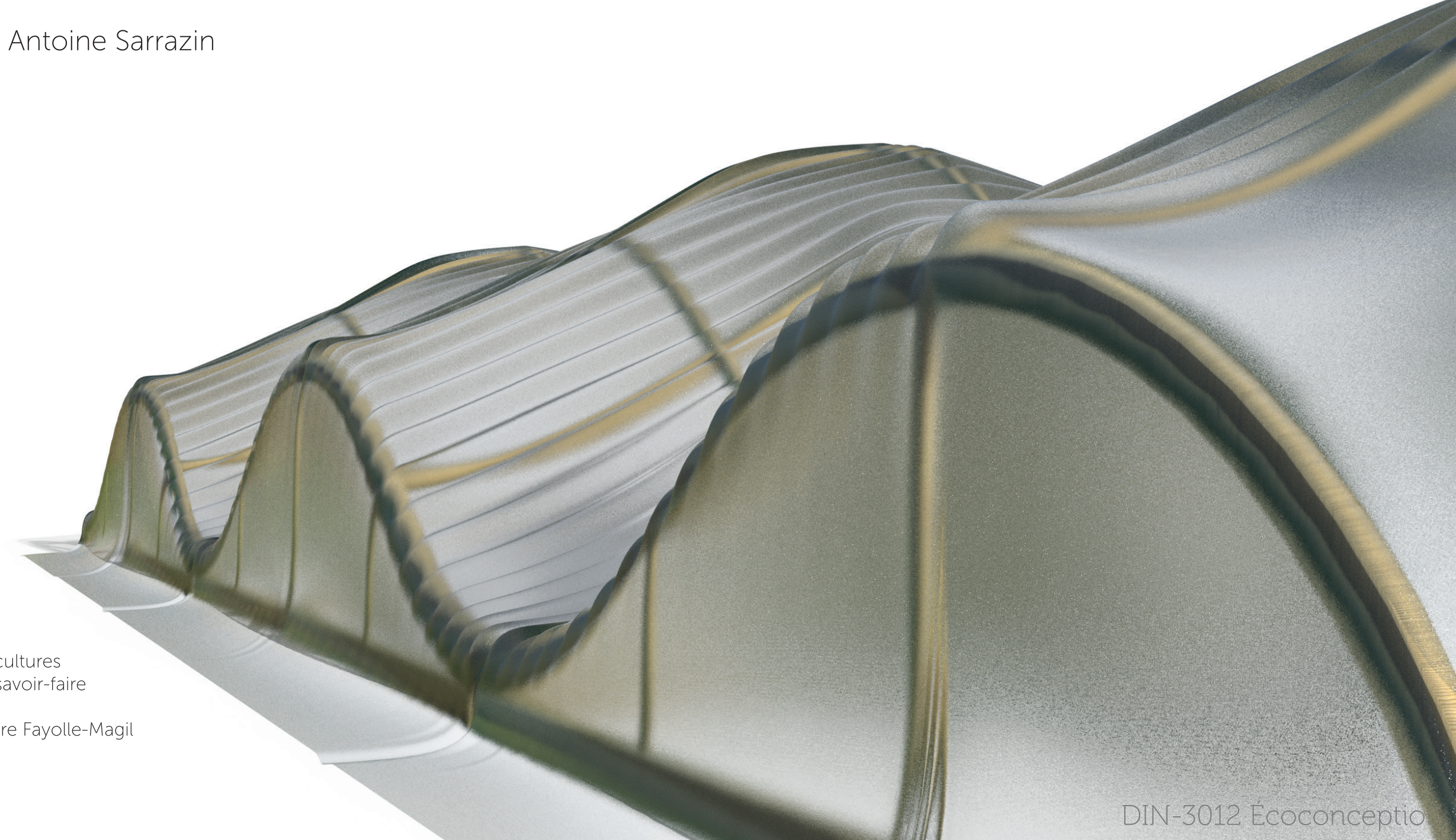

En collaboration avec

- Groupe de recherche design et cultures matérielles durables - Design et savoir-faire locaux
- LAB-BOIS laboratoire R&D / Chaire Fayolle-Magil Construction

# Contraintes

## 4 Saisons:

- Changement de culture
- Isolation
- Neige
- Accessibilité

## Plaines:

- Grand vent
- Peu/pas d'ombre

## Semi-Encastrée:

- Géothermie
- Régulation de température
- Limite la dépendance électrique

## Contexte:

- Serre communautaire

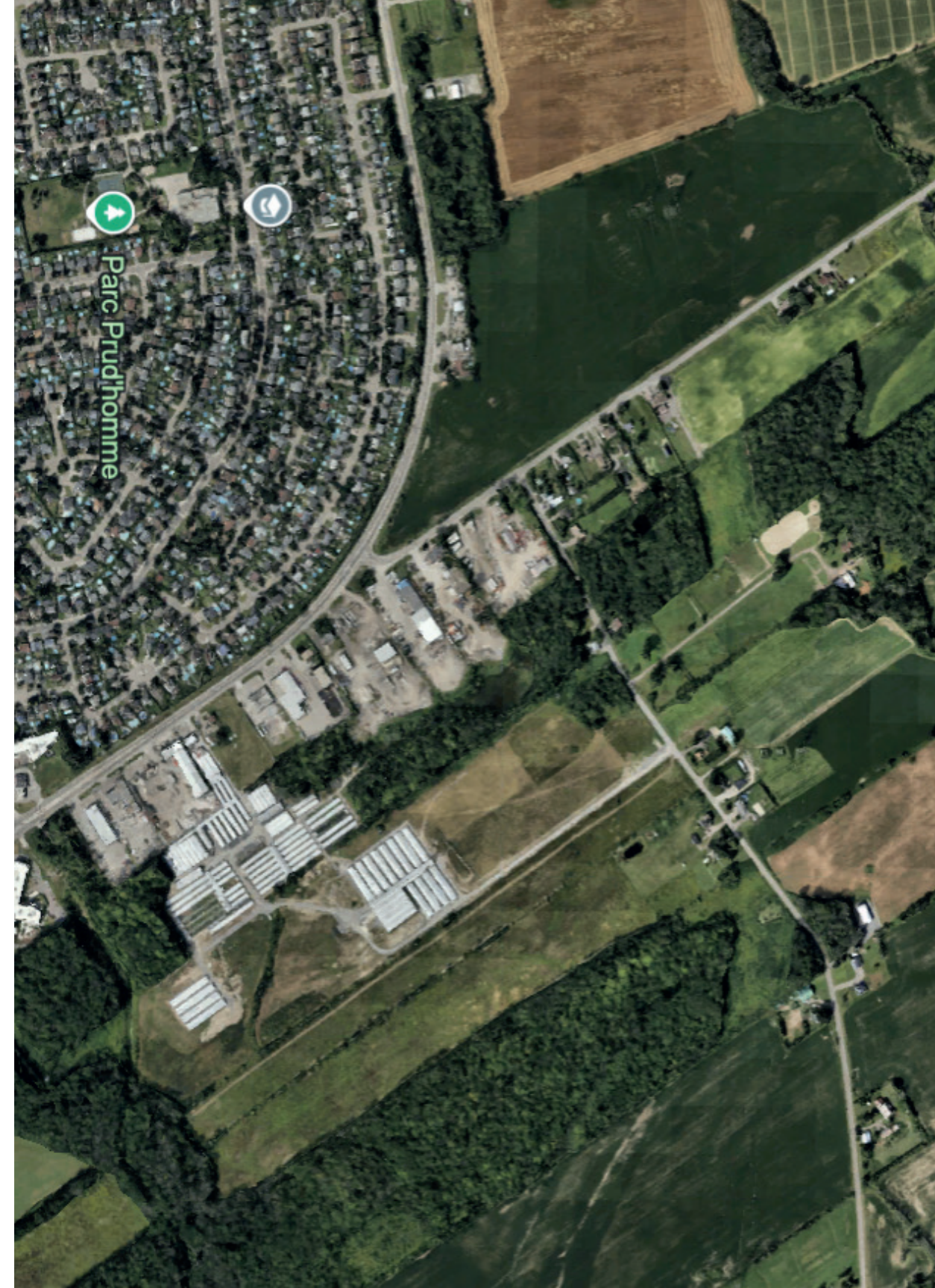

# Cultures visées

Estivale



Hivernale



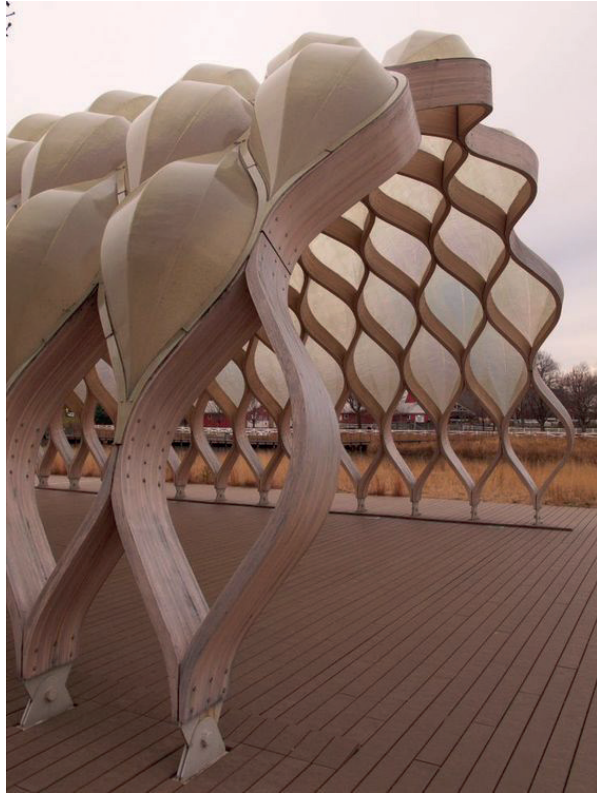

# Sketch

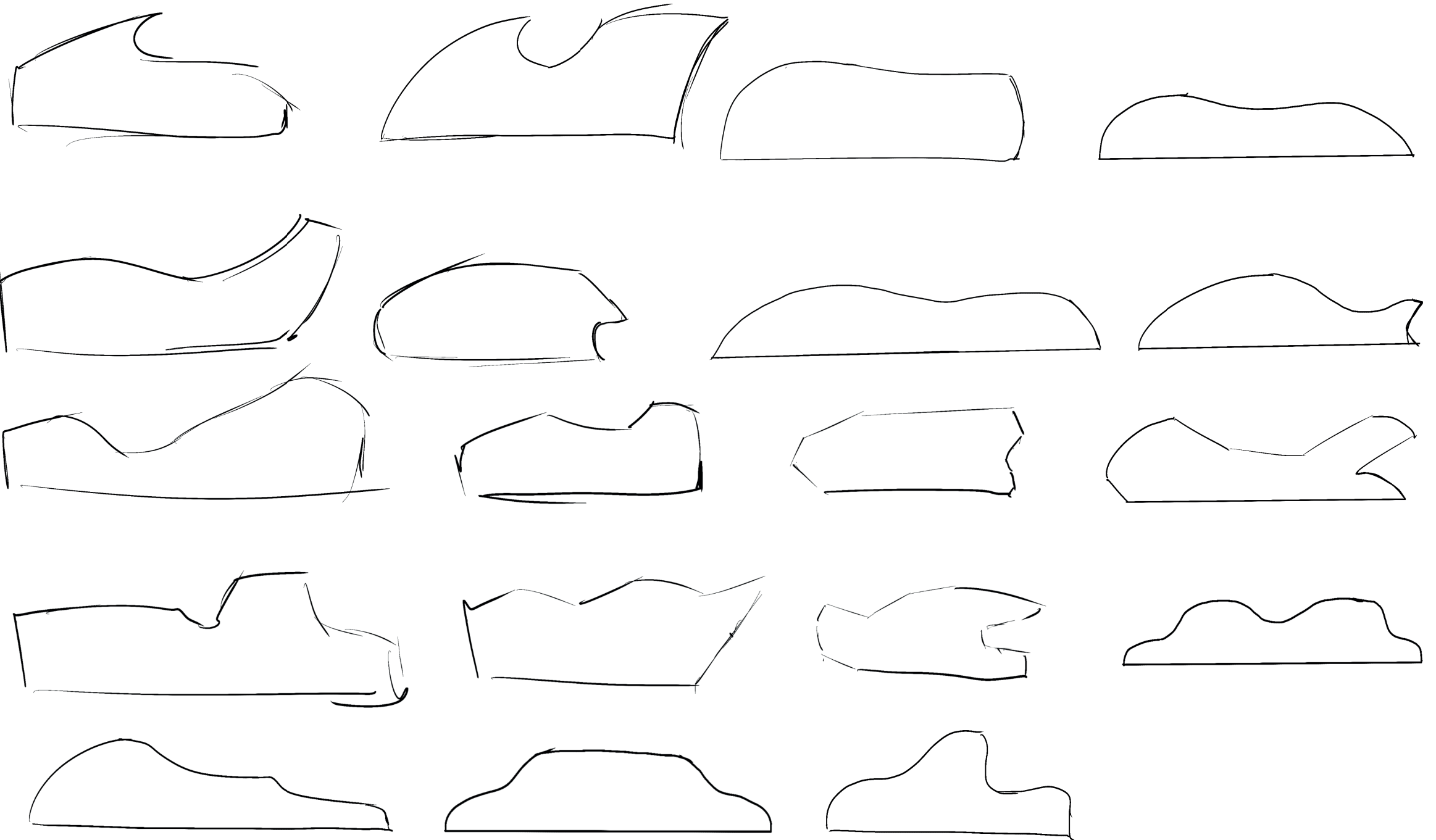

# Sketch

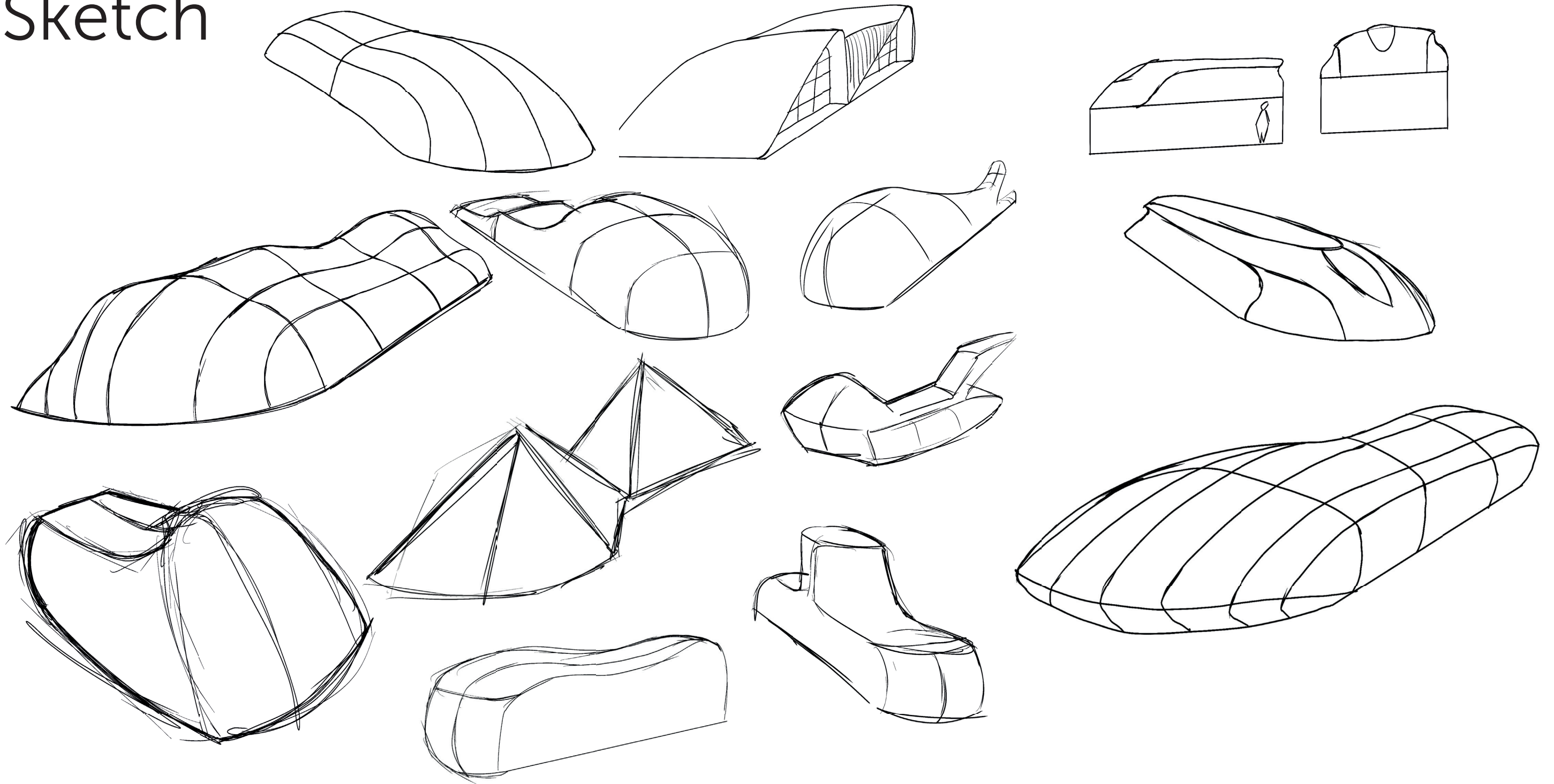

# Sketch

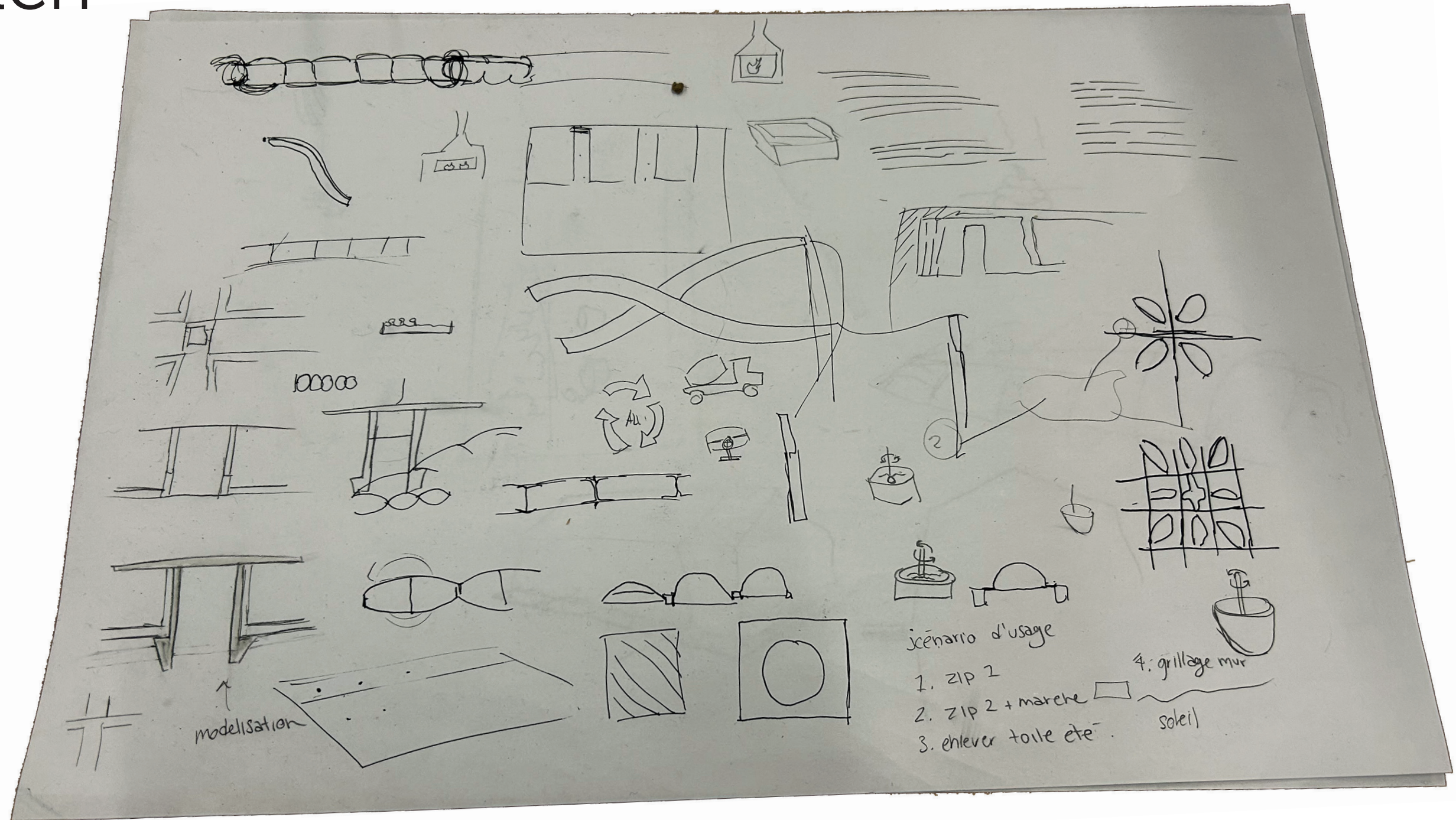

# Sketch

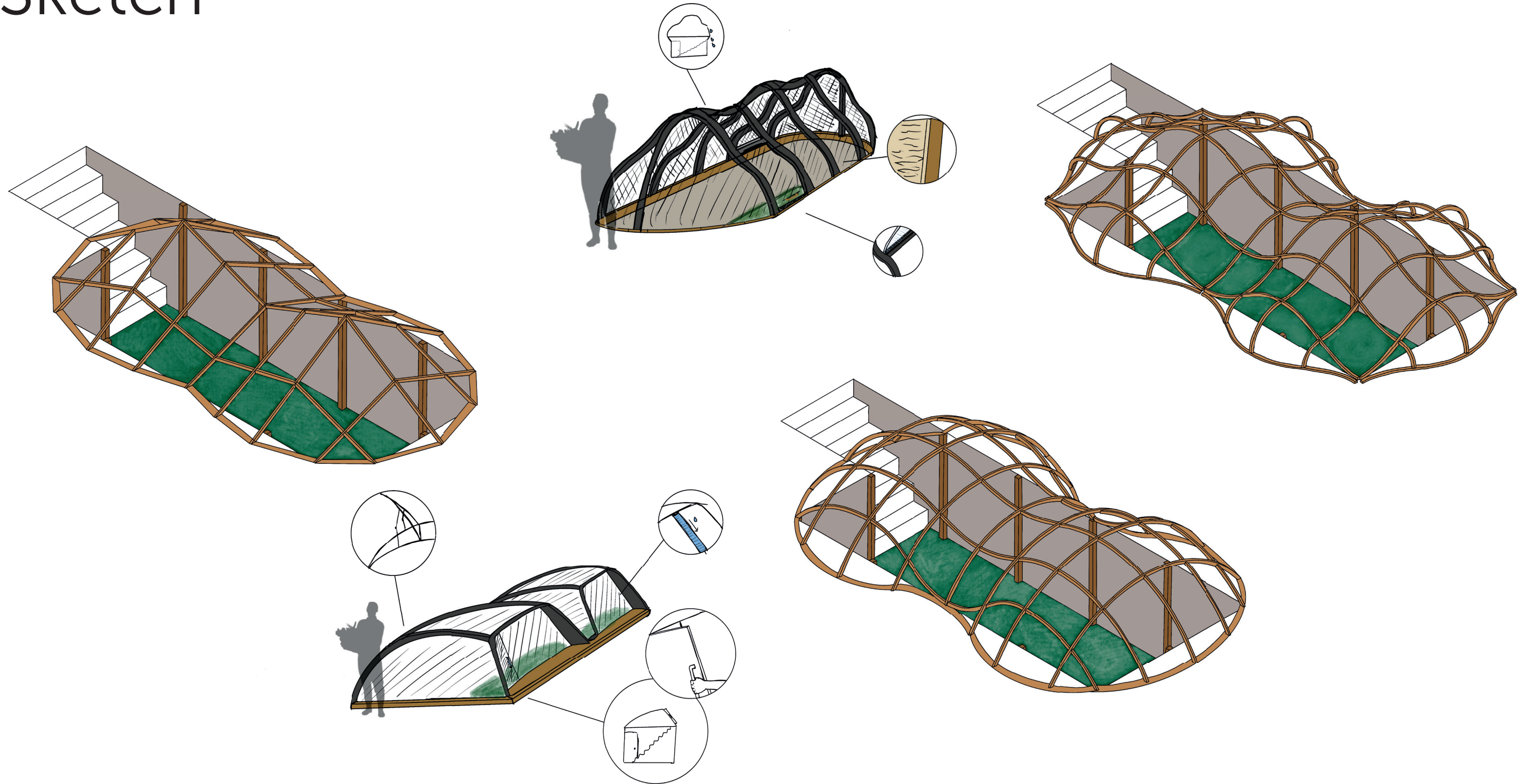



# Sketch final

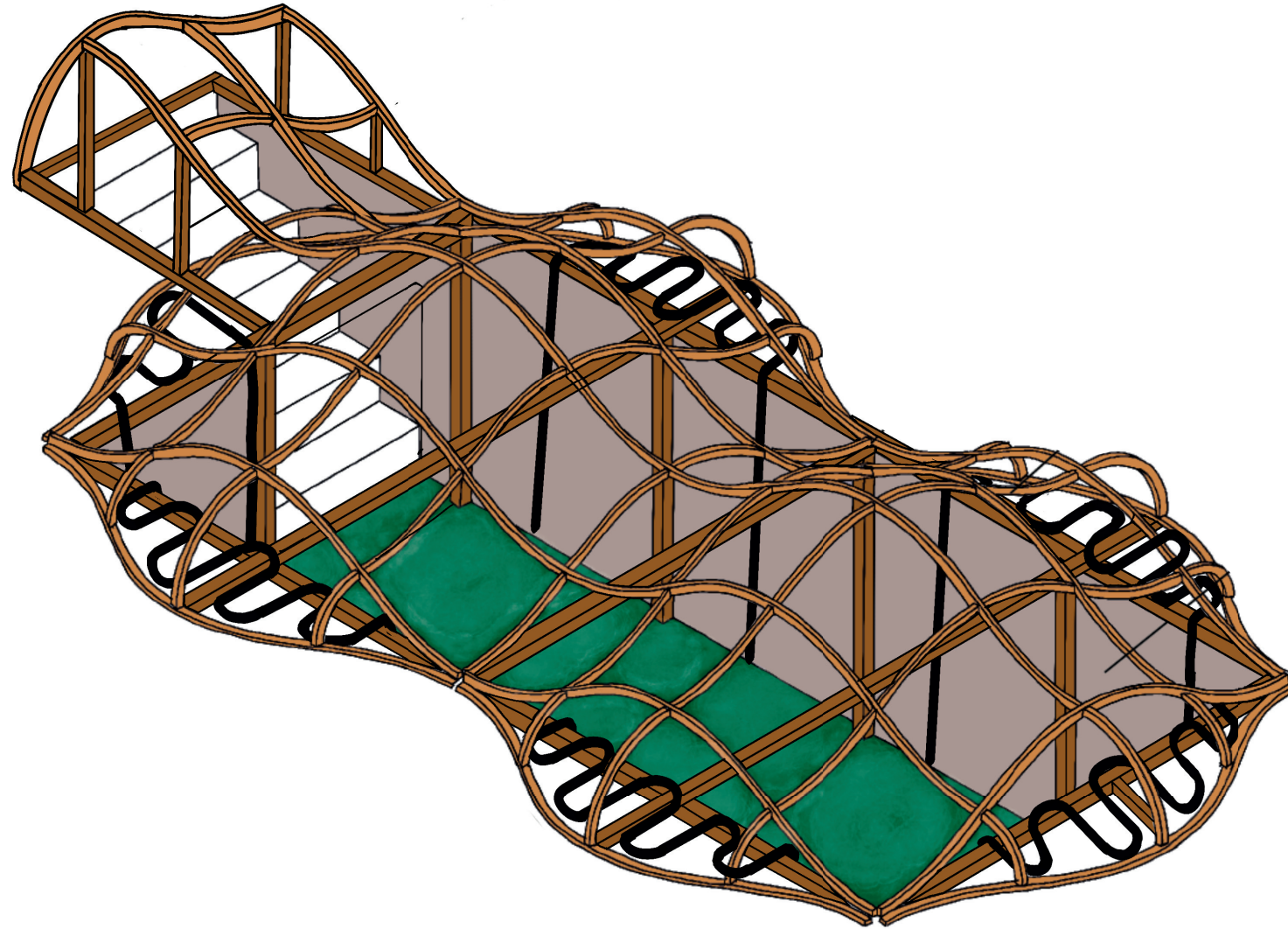

# Modélisation 3D

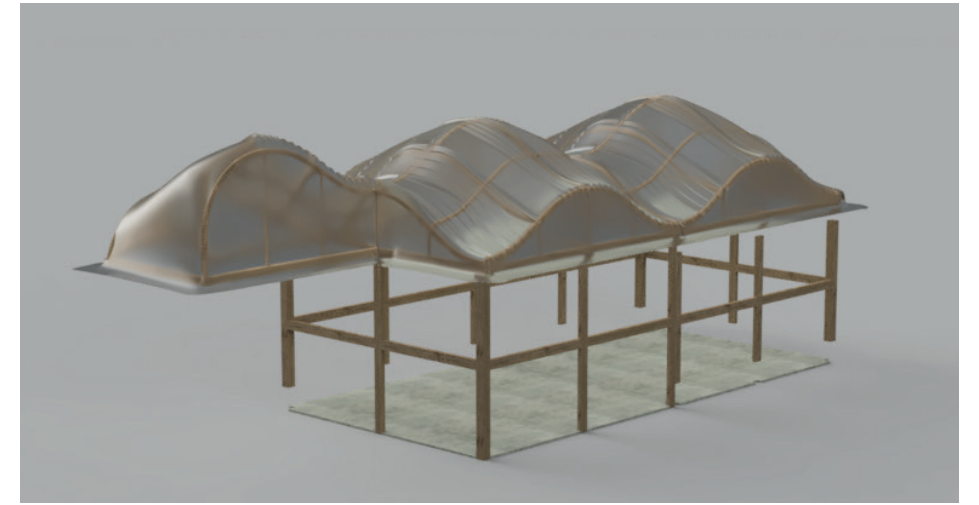
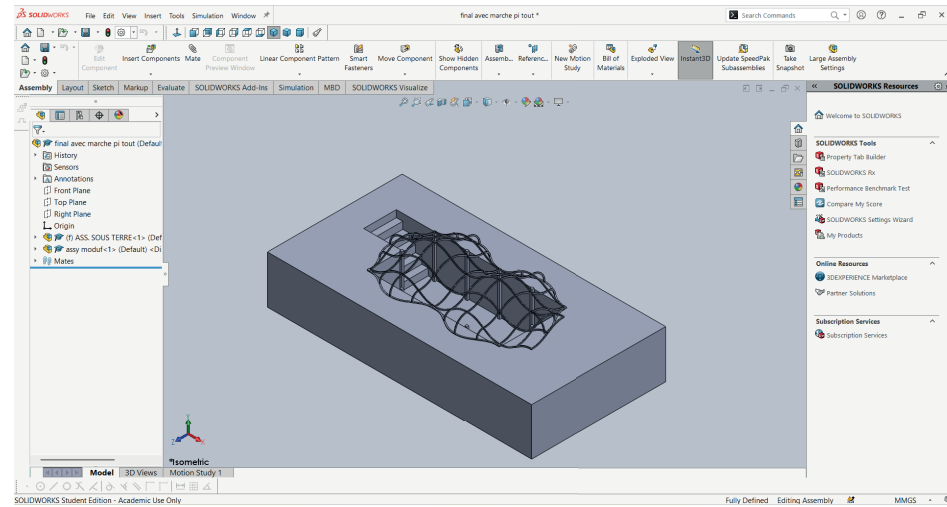

# Maquettes

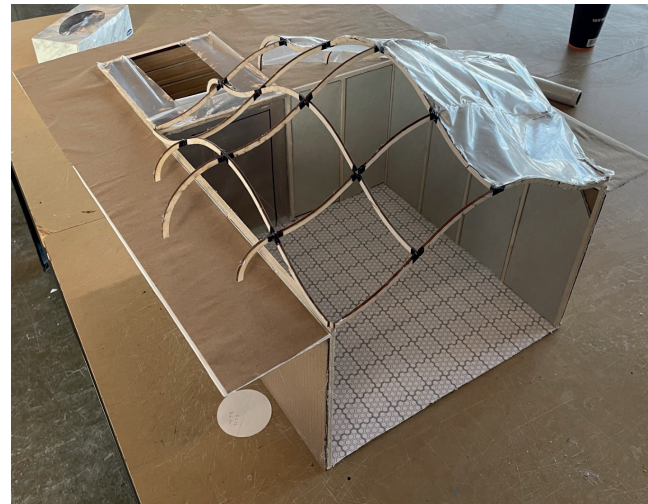
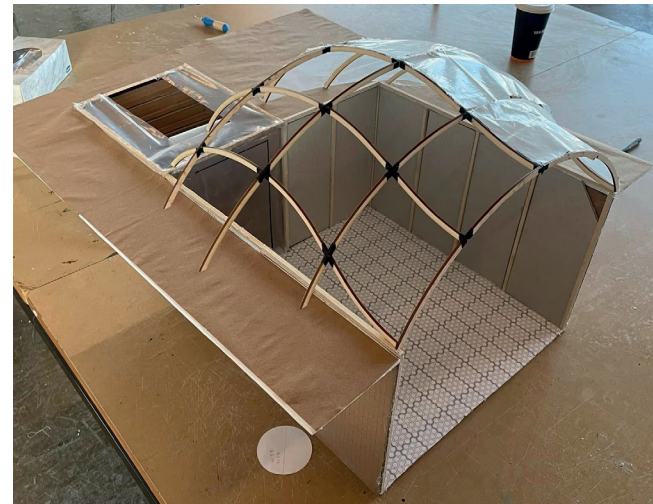
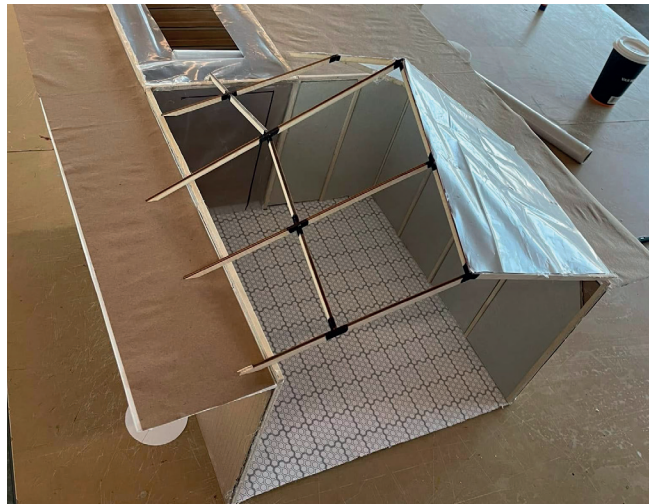
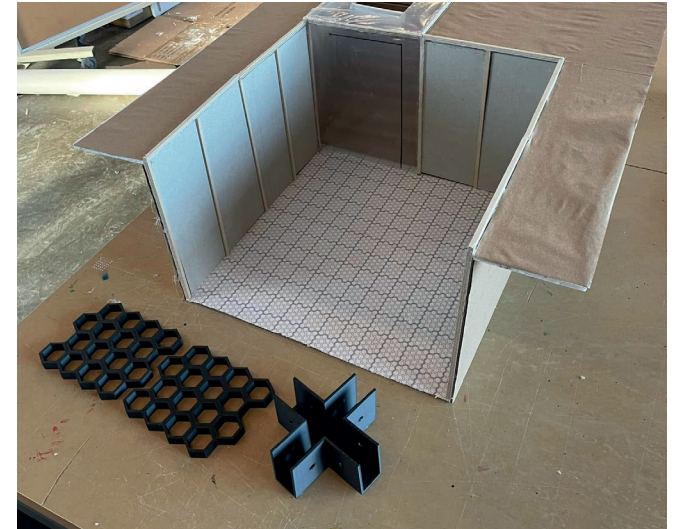
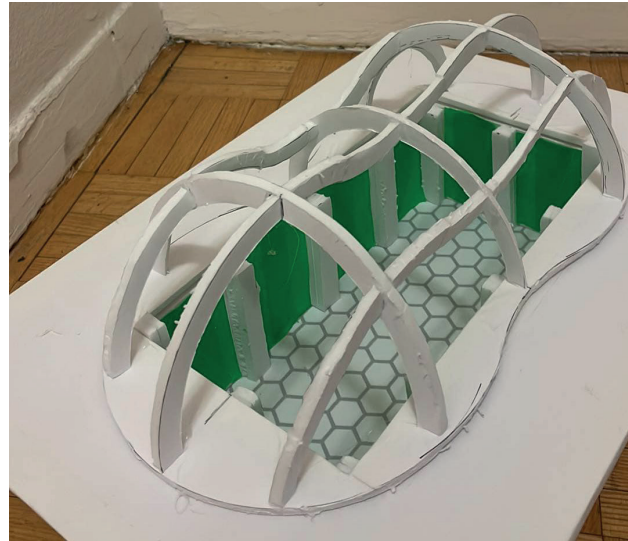

# Maquettes

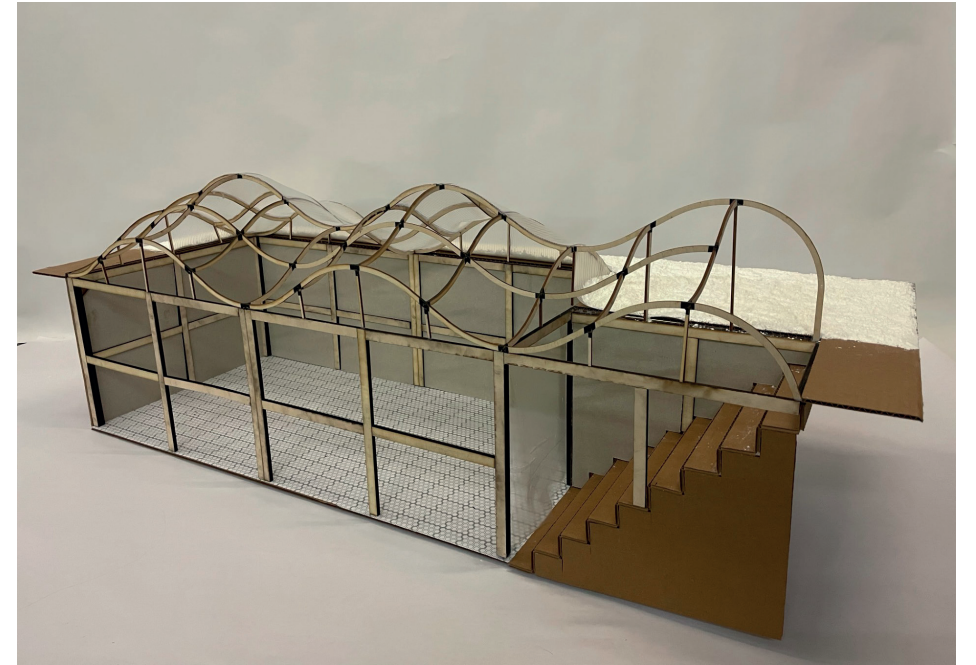
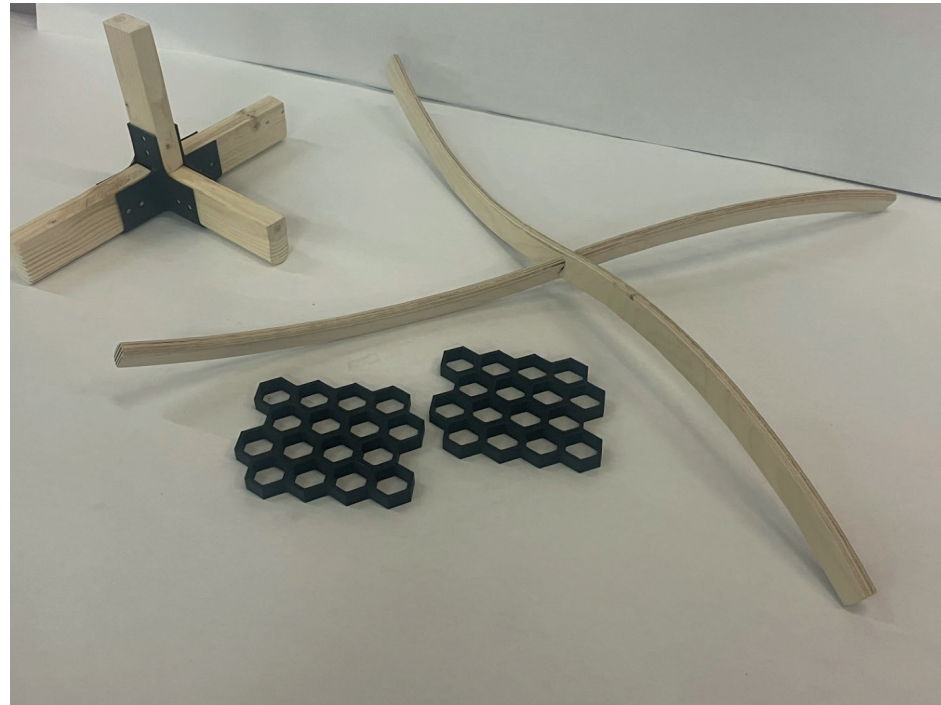
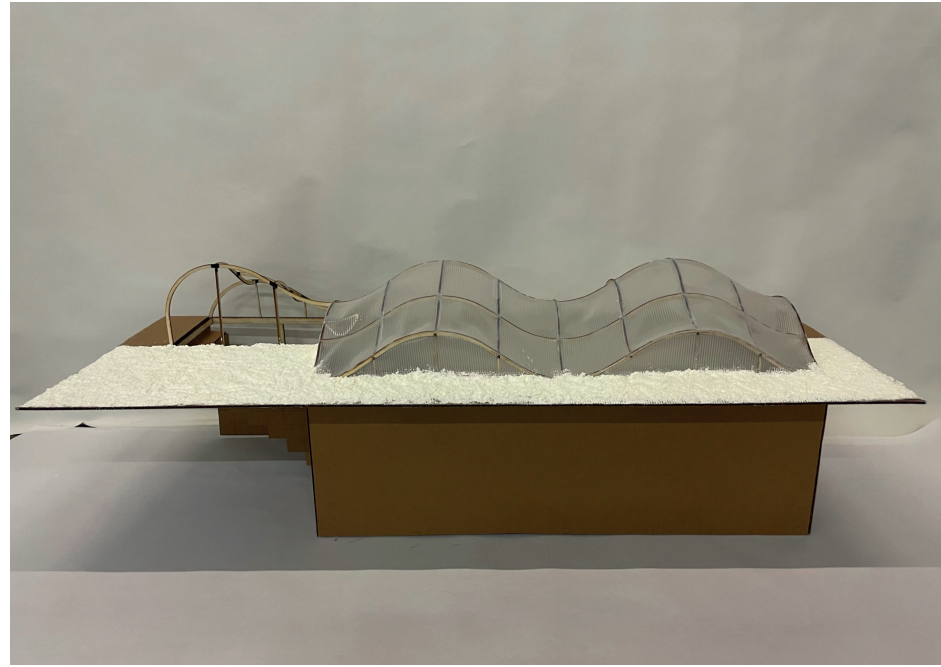

# Maquettes

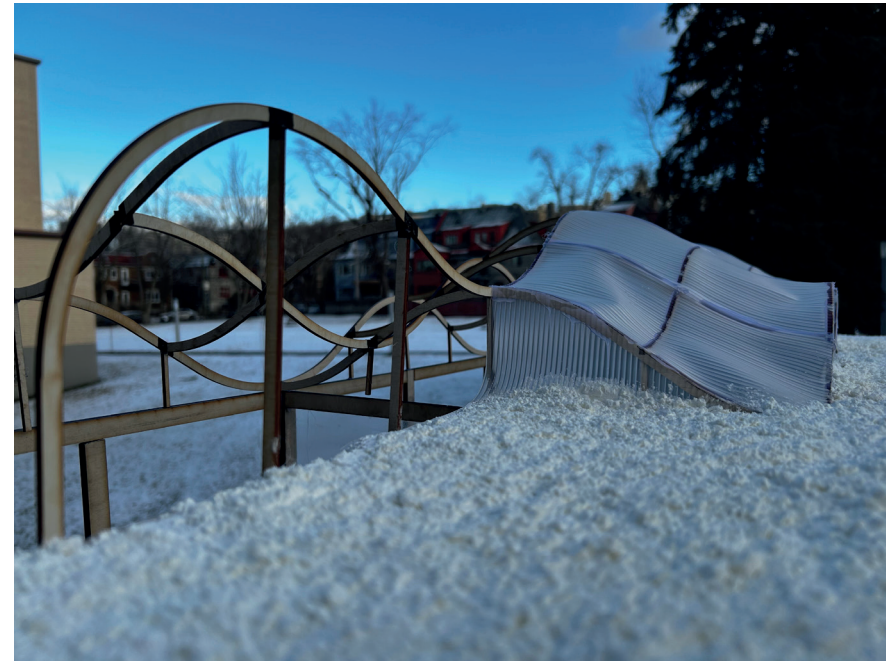

# Ateliers

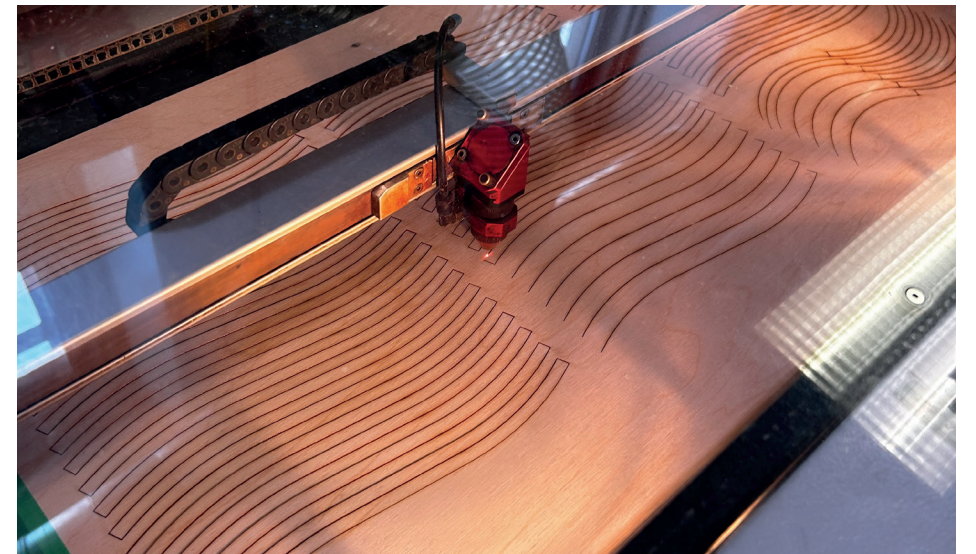
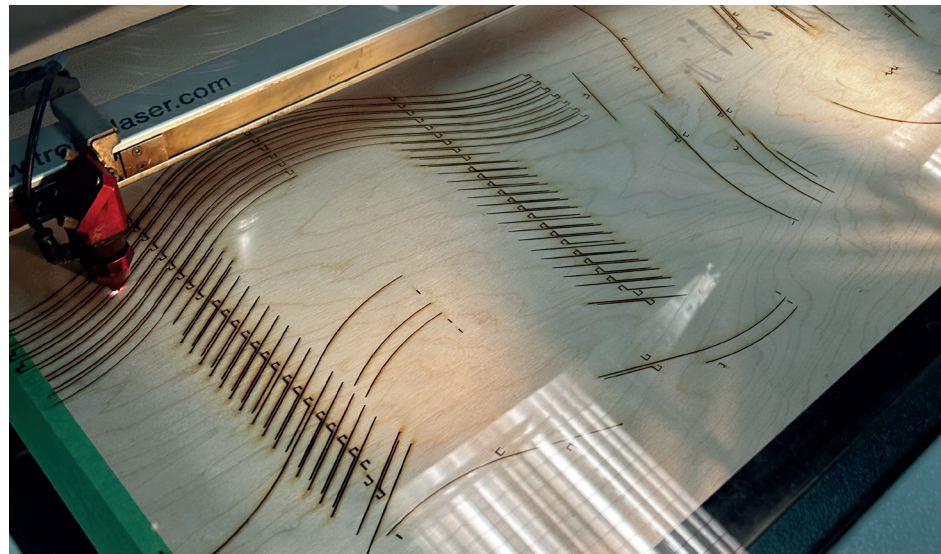
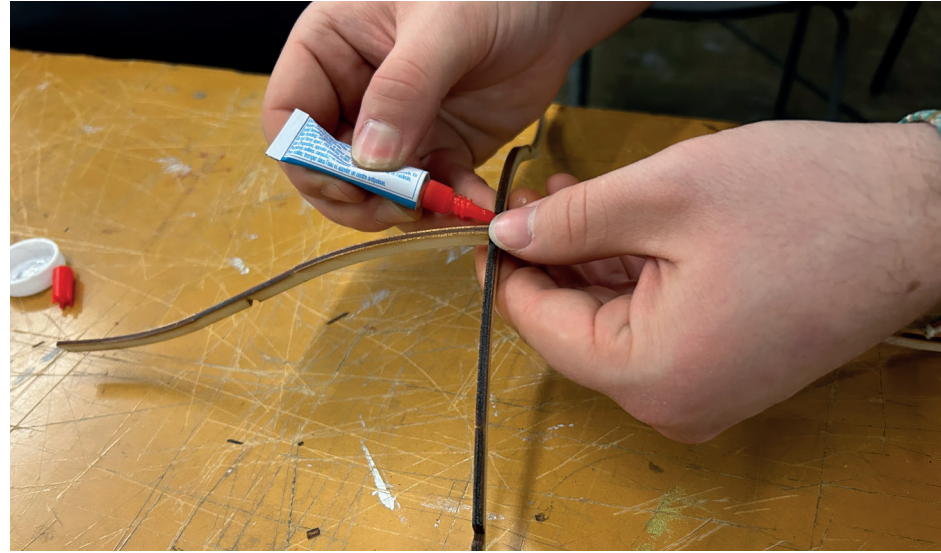

Iqaluk

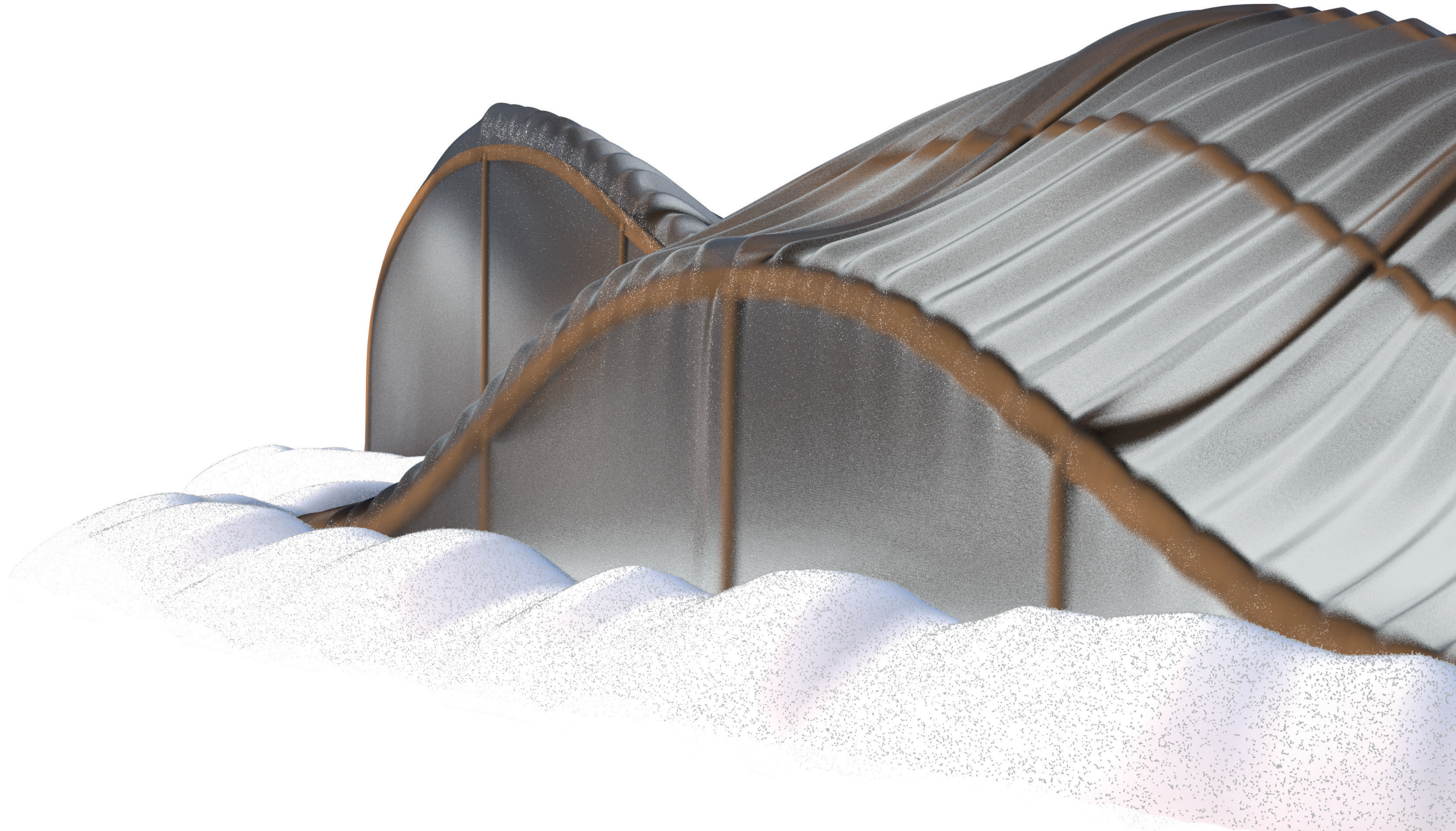

# Détails

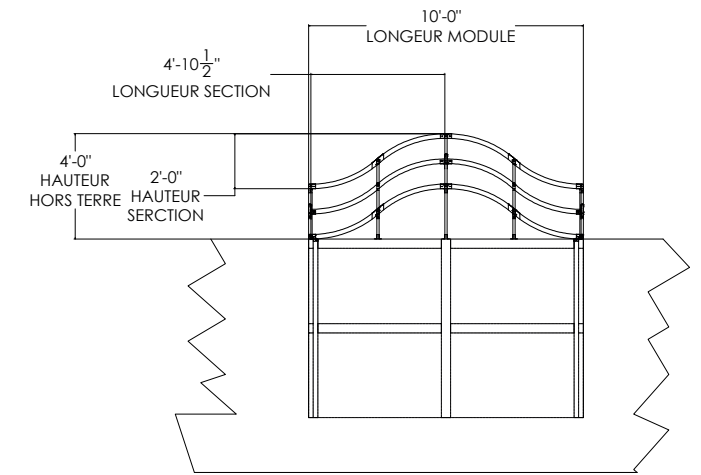
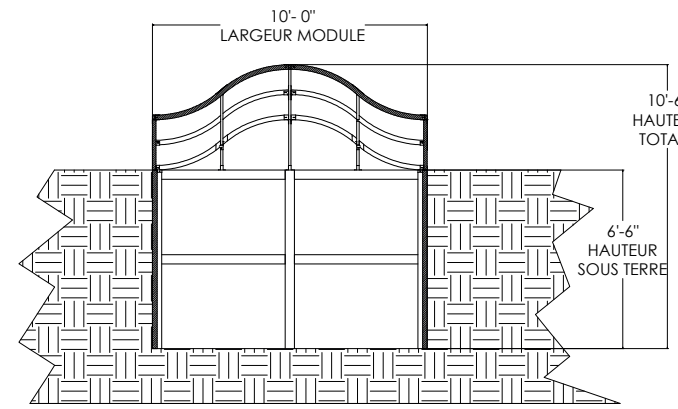
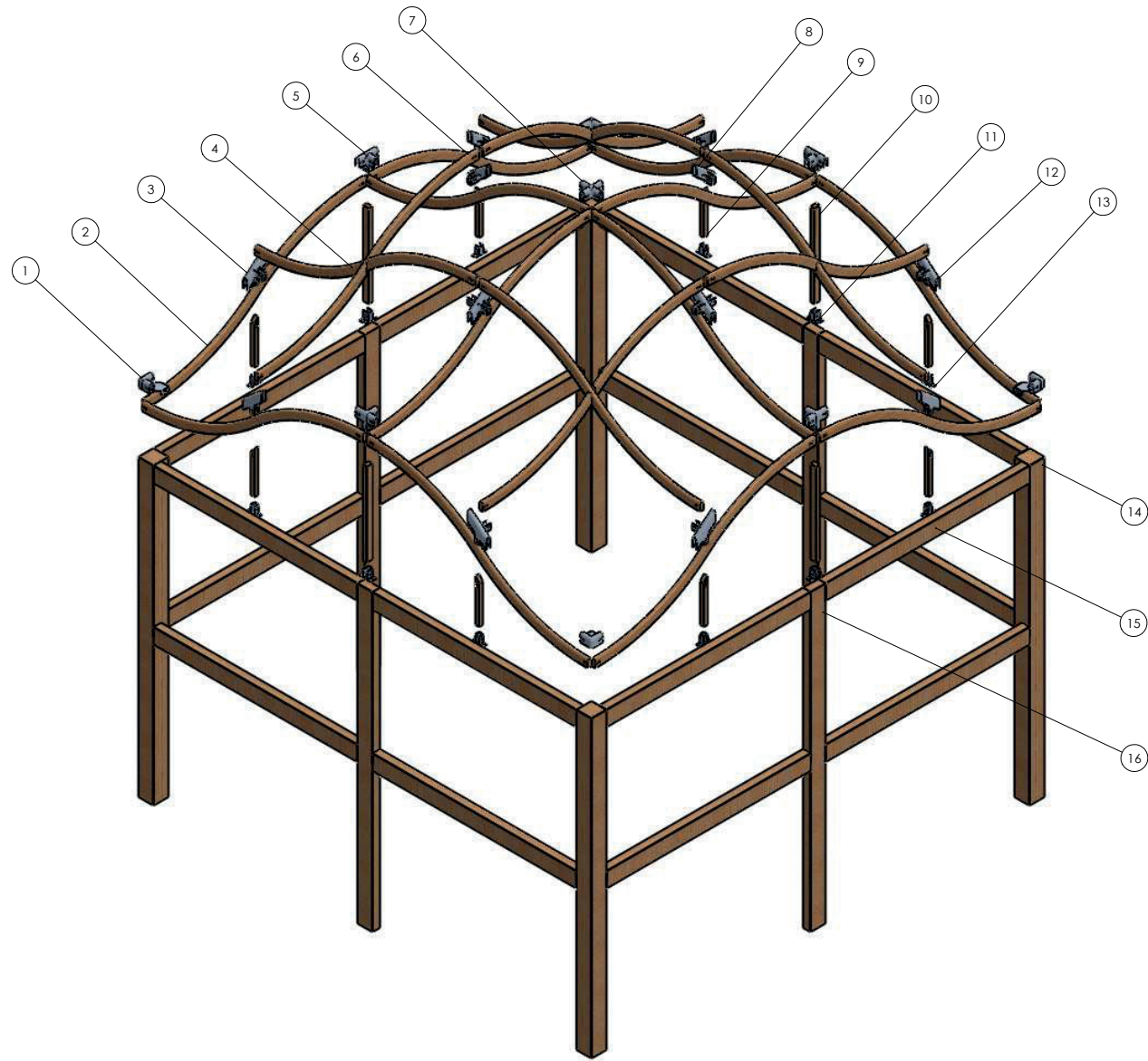

#	PIÈCE	MATÉRIEL	FINI	QUANTITÉ
1	JOINT COIN	ALUMINIUM	ANODISÉ NOIR	4
2	SECTION EXTERNE	LAMELLÉ-COLLÉ CÈDRE	TRAITÉ	12
3	JOINT MI-SECTION GAUCHE	ALUMINIUM	ANODISÉ NOIR	4
4	SECTION INTERNE INFÉRIEURE	LAMELLÉ-COLLÉ CÈDRE	TRAITÉ	4
5	JOINT SECTION TRIPLE	ALUMINIUM	ANODISÉ NOIR	8
6	SECTION INTERNE SUPÉRIEURE	LAMELLÉ-COLLÉ CÈDRE	TRAITÉ	4
7	JOINT SECTION QUADRUPLE	ALUMINIUM	ANODISÉ NOIR	1
8	JOINT MI-SECTION CENTRAL	ALUMINIUM	ANODISÉ NOIR	4
9	POTEAU LIAISON EXTERNE	LAMELLÉ-COLLÉ CÈDRE	TRAITÉ	8
10	POTEAU LIAISON INTERNE	LAMELLÉ-COLLÉ CÈDRE	TRAITÉ	4
11	JOINT BASE INTERNE	ALUMINIUM	ANODISÉ NOIR	4
12	JOINT MI-SECTION DROIT	ALUMINIUM	ANODISÉ NOIR	4
13	JOINT BASE EXTERNE	ALUMINIUM	ANODISÉ NOIR	8
14	POTEAU STRUCTUREL EXTERNE	CÈDRE	TRAITÉ	4
15	POTEAU STRUCTUREL TRANSVERSAL	CÈDRE	TRAITÉ	16
16	POTEAU STRUCTUREL INTERNE	CÈDRE	TRAITÉ	4



# Détails

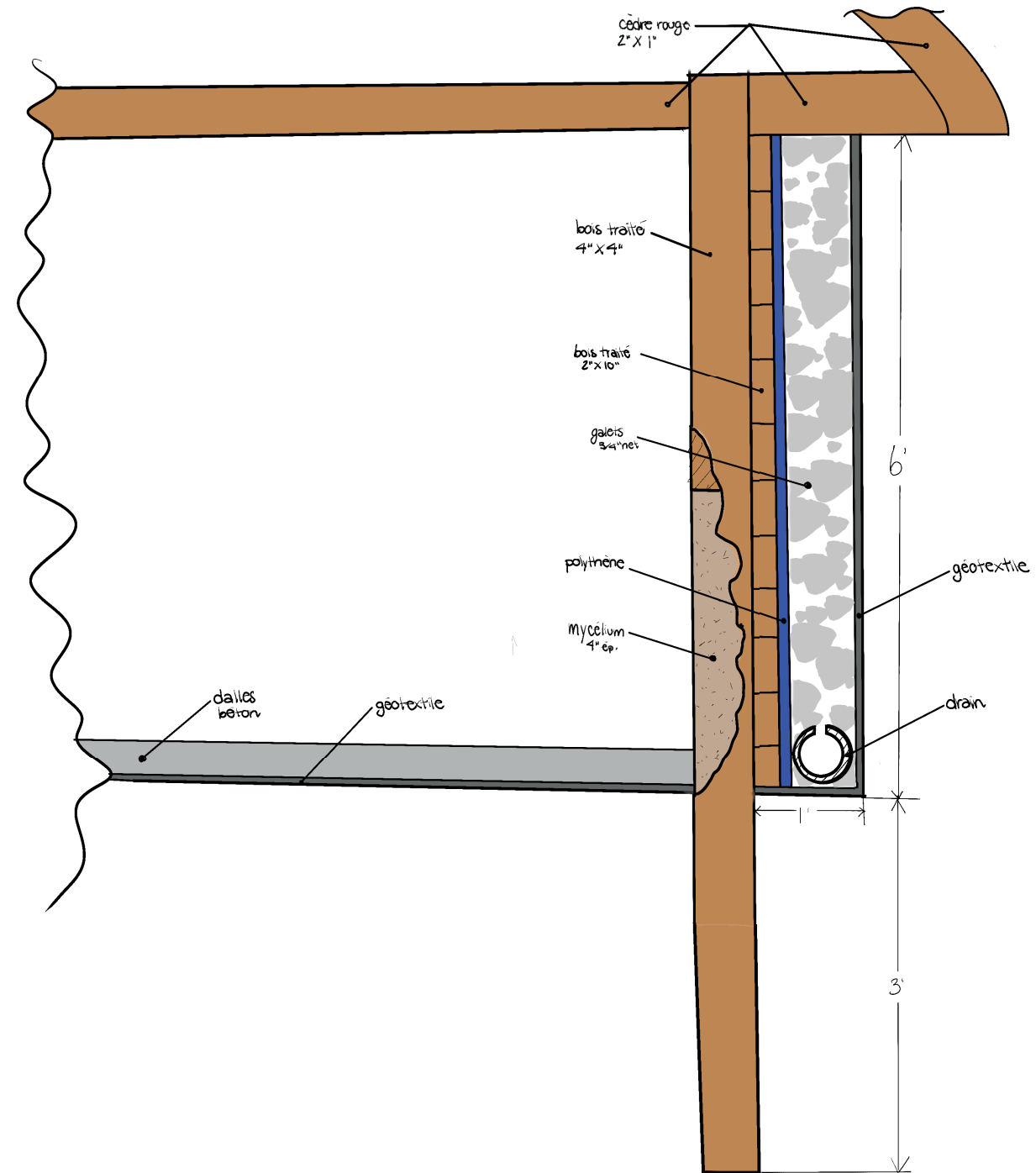

# Détails

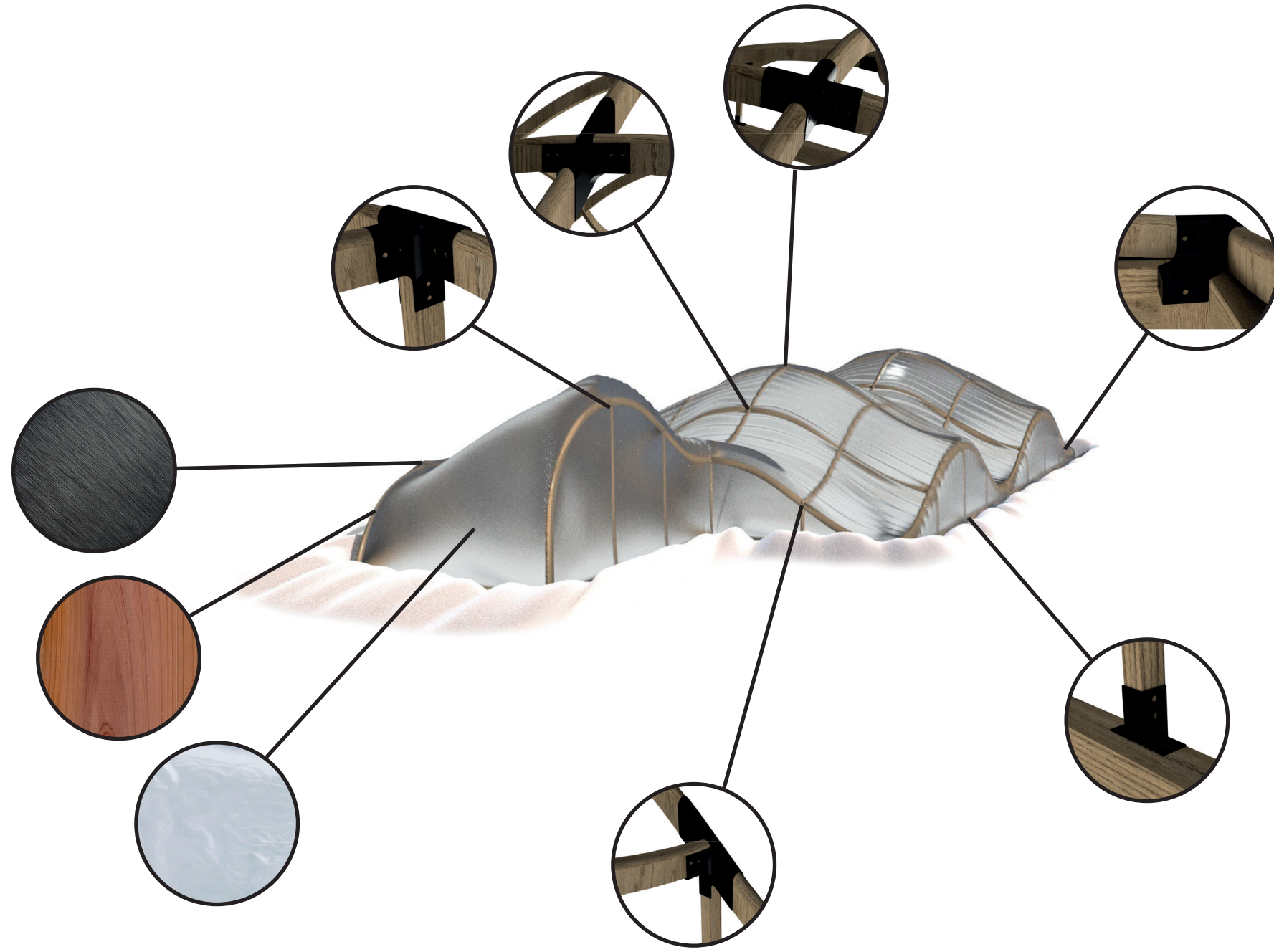

# Assemblage

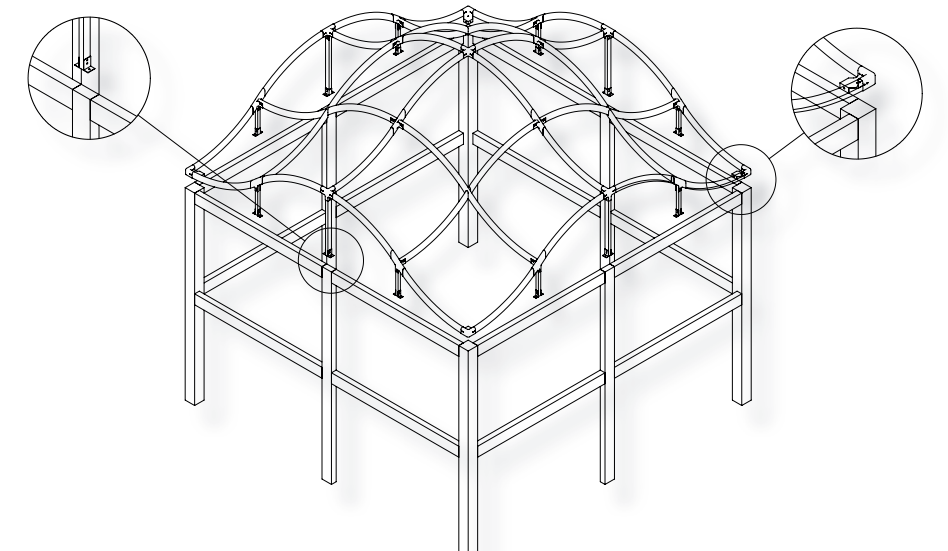
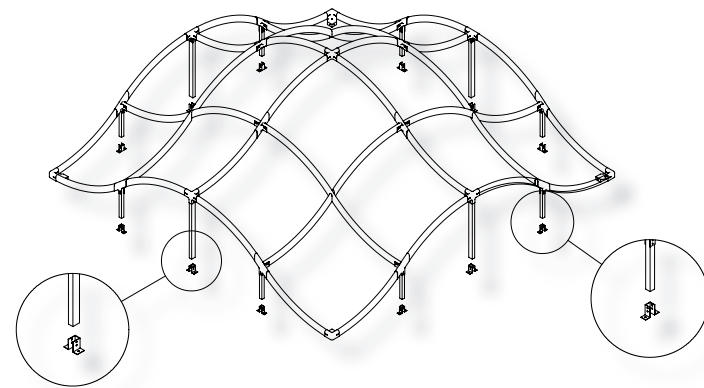
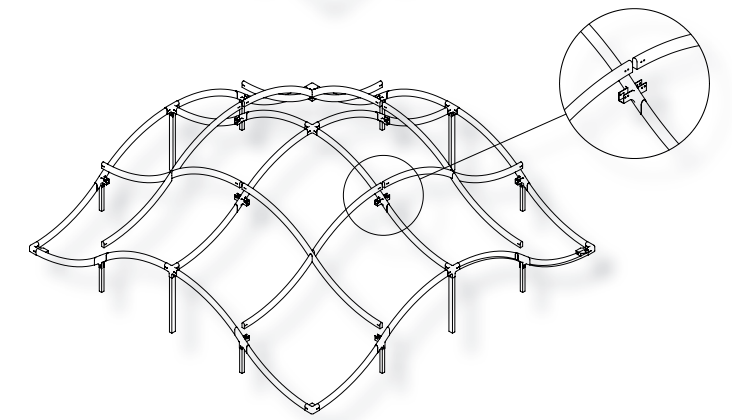
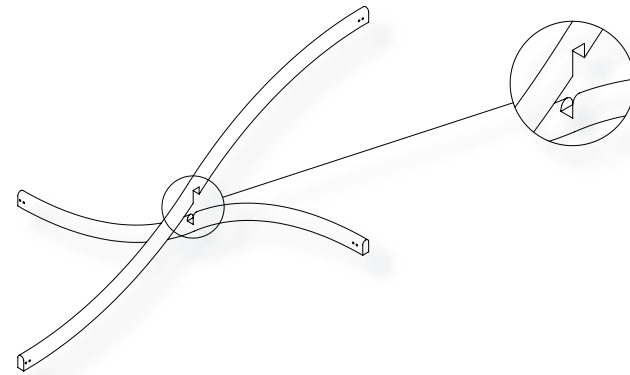
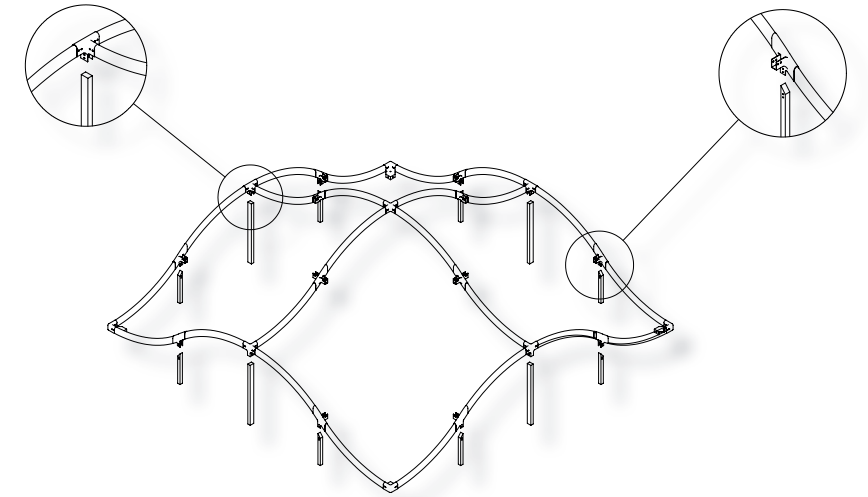
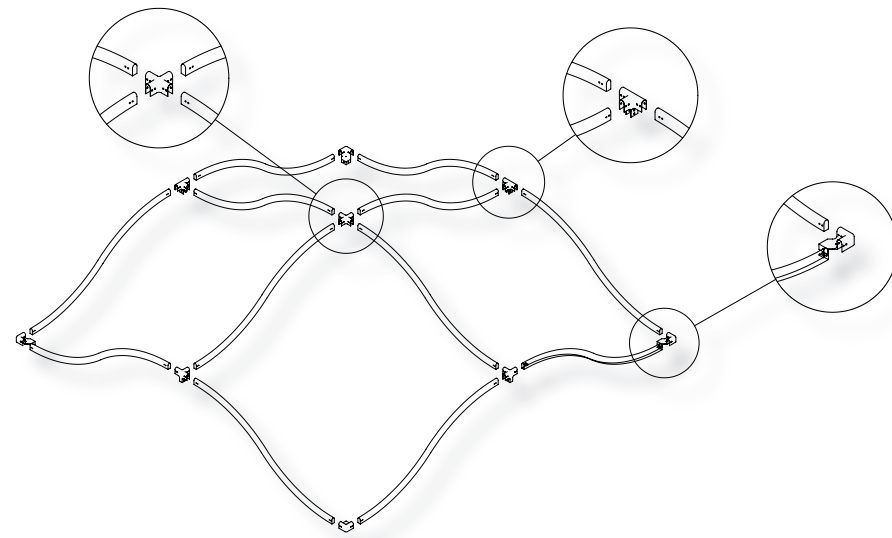

# Détails

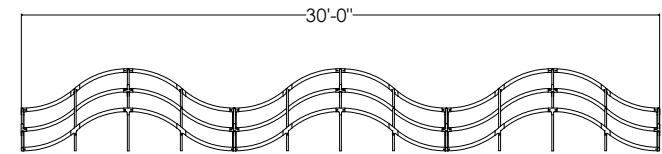
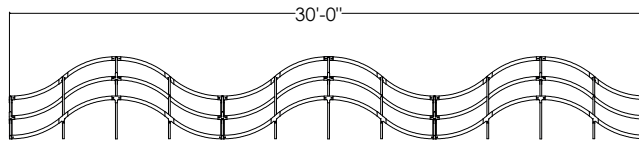
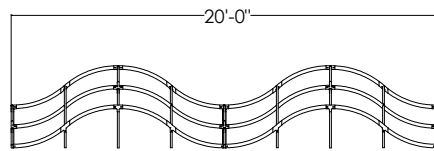
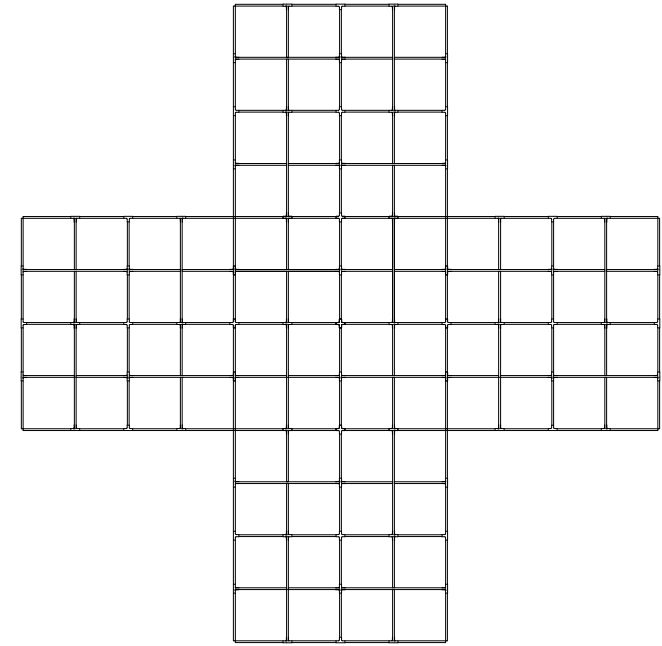
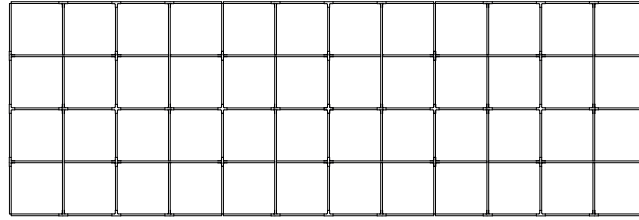
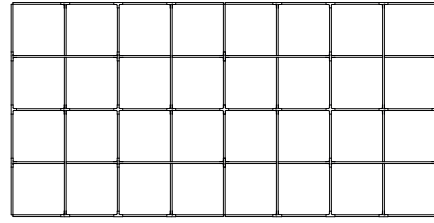



# Scénario d'usage

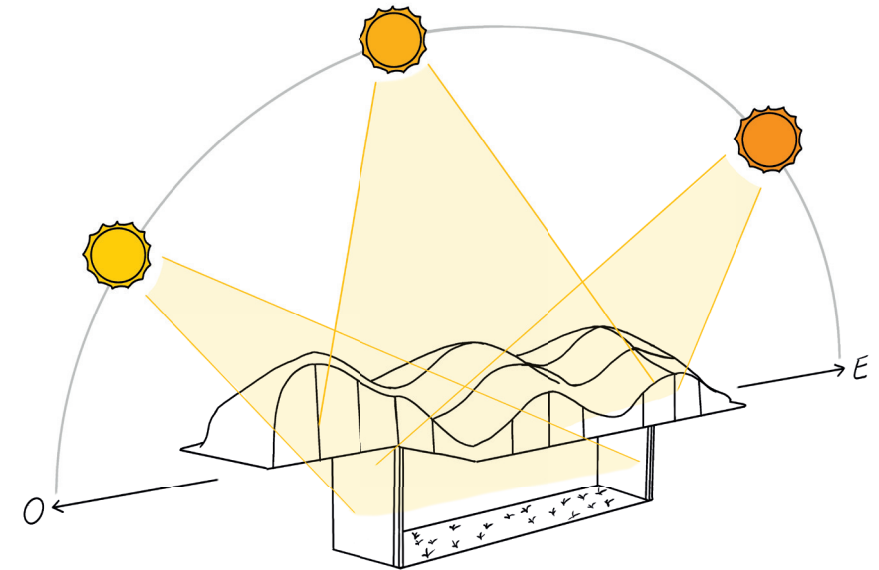
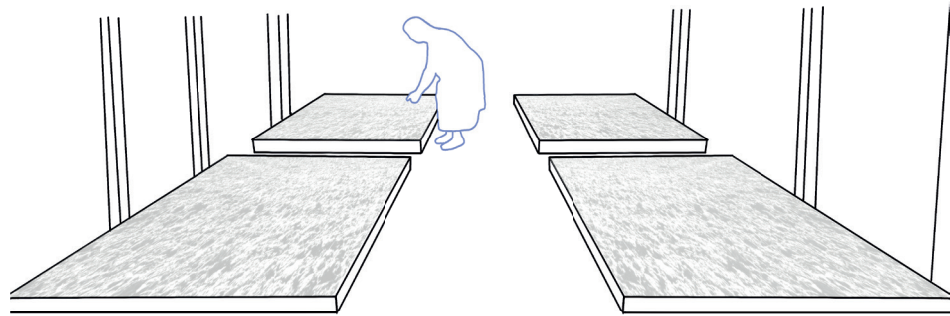
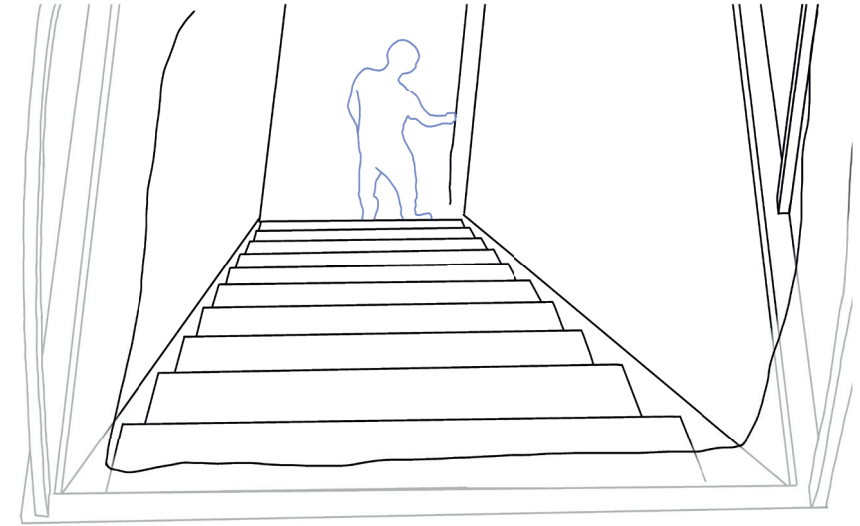
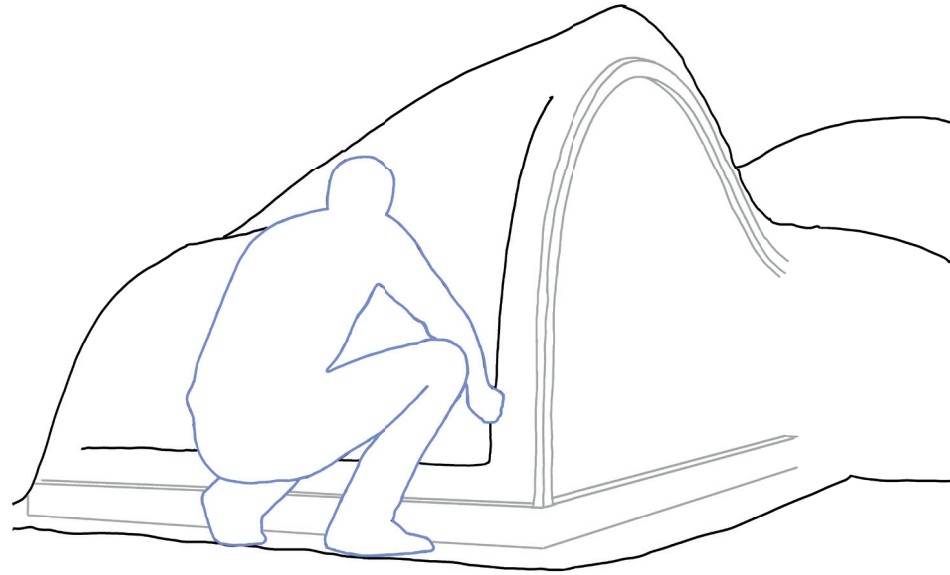

# Unpacking

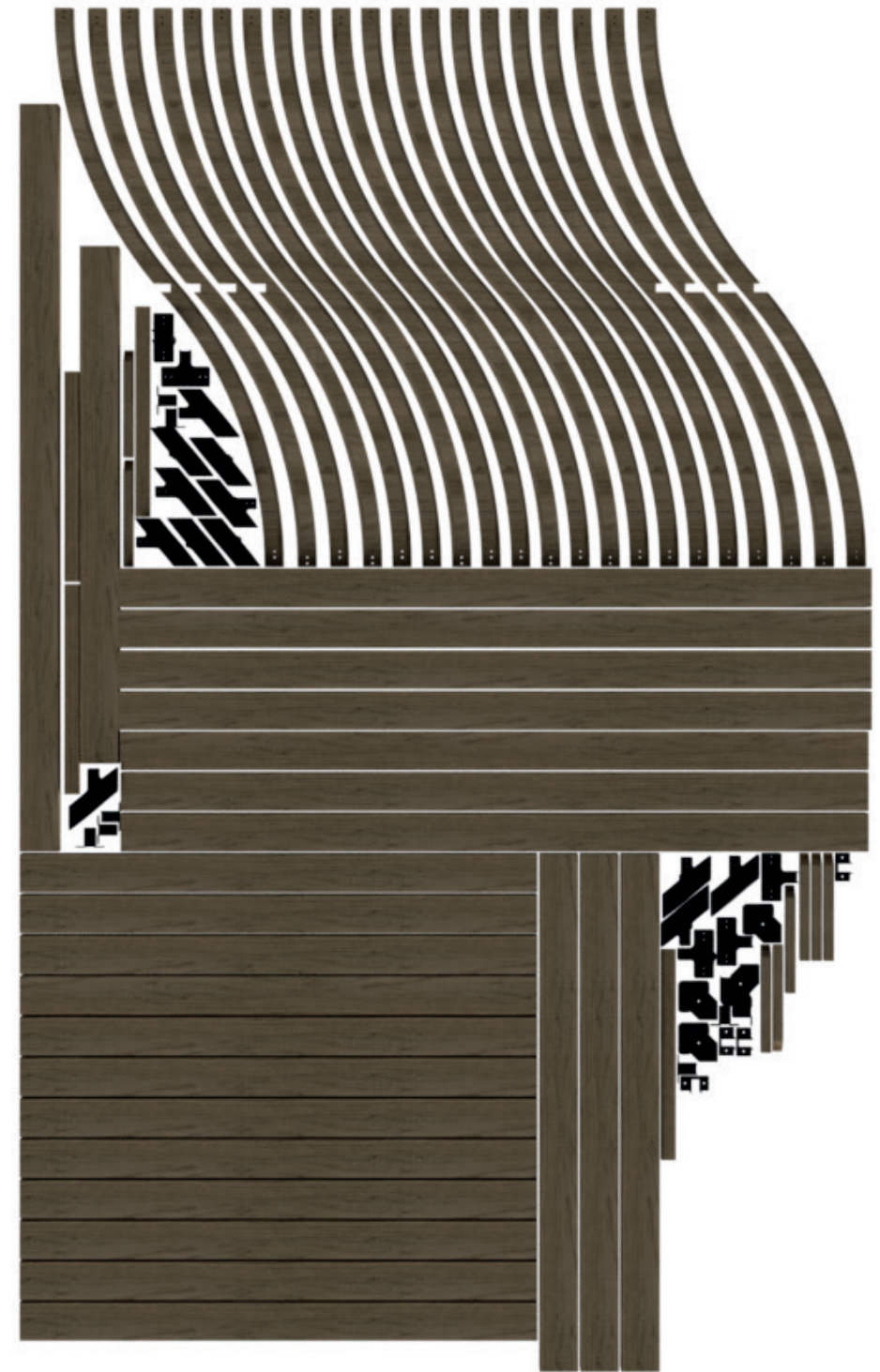

# Rendu

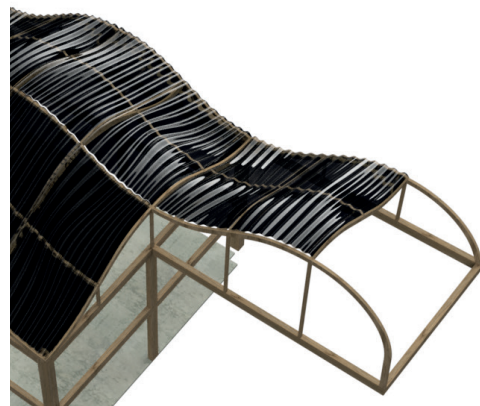
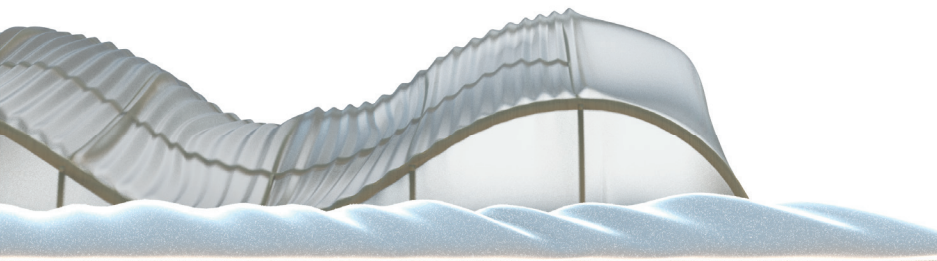
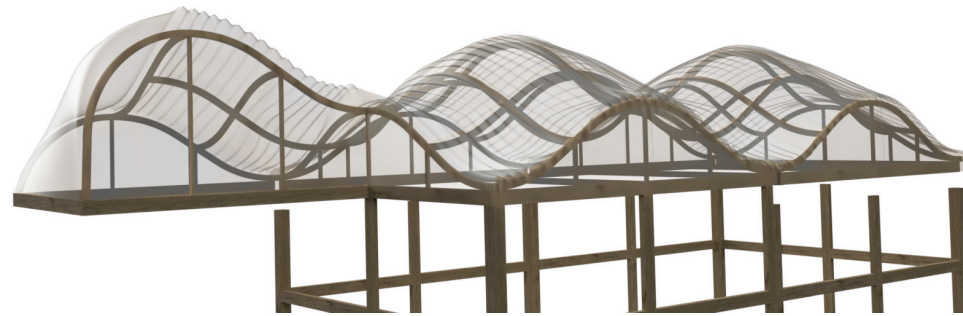
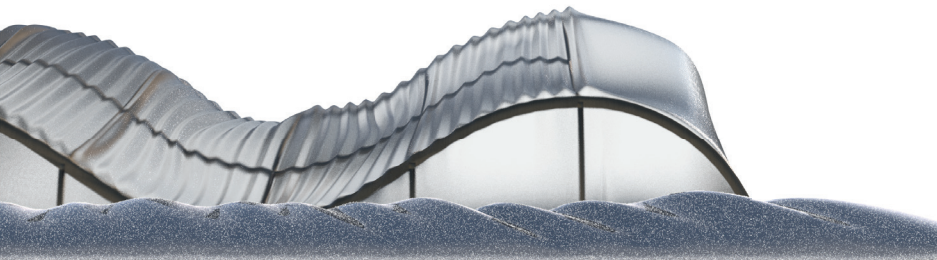
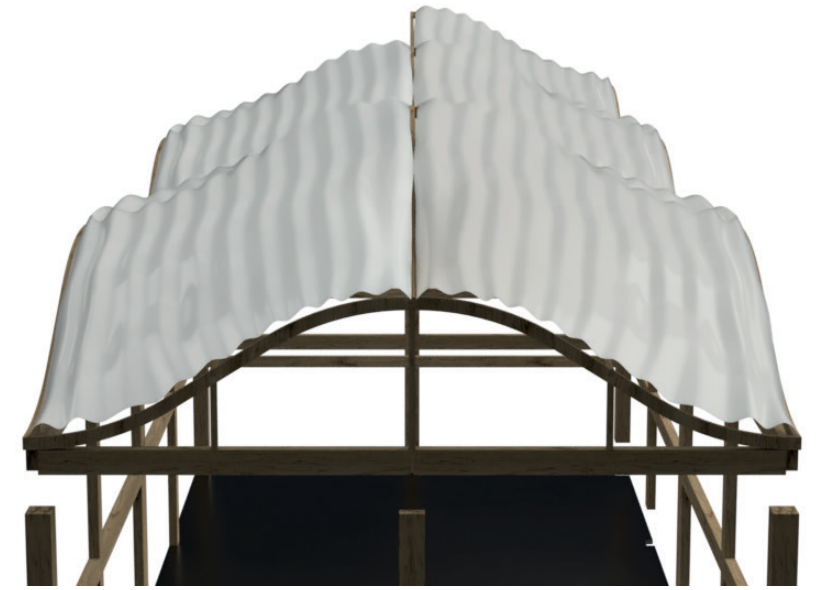



Iqaluk



Iqaluk



# Iqaluk

